

The Ray Allen Company Inc.

1341 Distribution Way Ste 15, Vista, CA 92081 USA Ph 760 599 4720 Fx 760 599 4383

www.rayallencompany.com

REL-2 SERVO RELAY DECK

The REL-2 Relay Deck is designed to convert SPDT action switches into a DPDT action. The REL-2 will also drop both power white power leads going to the servo motor to ground. This motor braking function enables very precise servo positioning.

INSTALLATION INSTRUCTIONS

Secure the relay deck to the airframe or simply tie it onto a bundle of wires. Do not install the REL-2 where it is exposed to excessive heat or vibration. The REL-2 is rated at 1 amp. Fuses and circuit breakers are not included.

The REL-2 Relay Deck needs 12-14 VDC applied to the red wire to operate. There is a separate blue wire that sends power to the servo. If you are not using our SPD-1 servo speed control, tie these red and blue power wires together.

Wire according to **DIAGRAM 1** if you are installing a SPDT switch and one servo. Refer to **DIAGRAM 2** if you are using a ROS-4 4-way switch. Refer to **DIAGRAM 3** if you are using relays with a RAC stick grip.

NOTE: Test to determine if the servo(s) run in the direction that you desire. This direction can be changed by reversing the two white wires that connect the servo to the relay deck.

CAUTION!! Be careful that the two white wires running to the servo **do not touch ground or short together**. Do not power the relays with a battery charger.

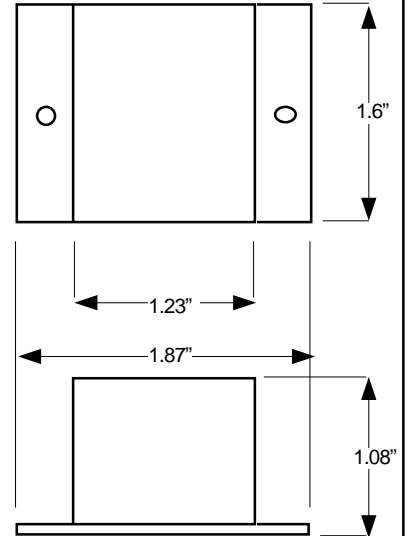
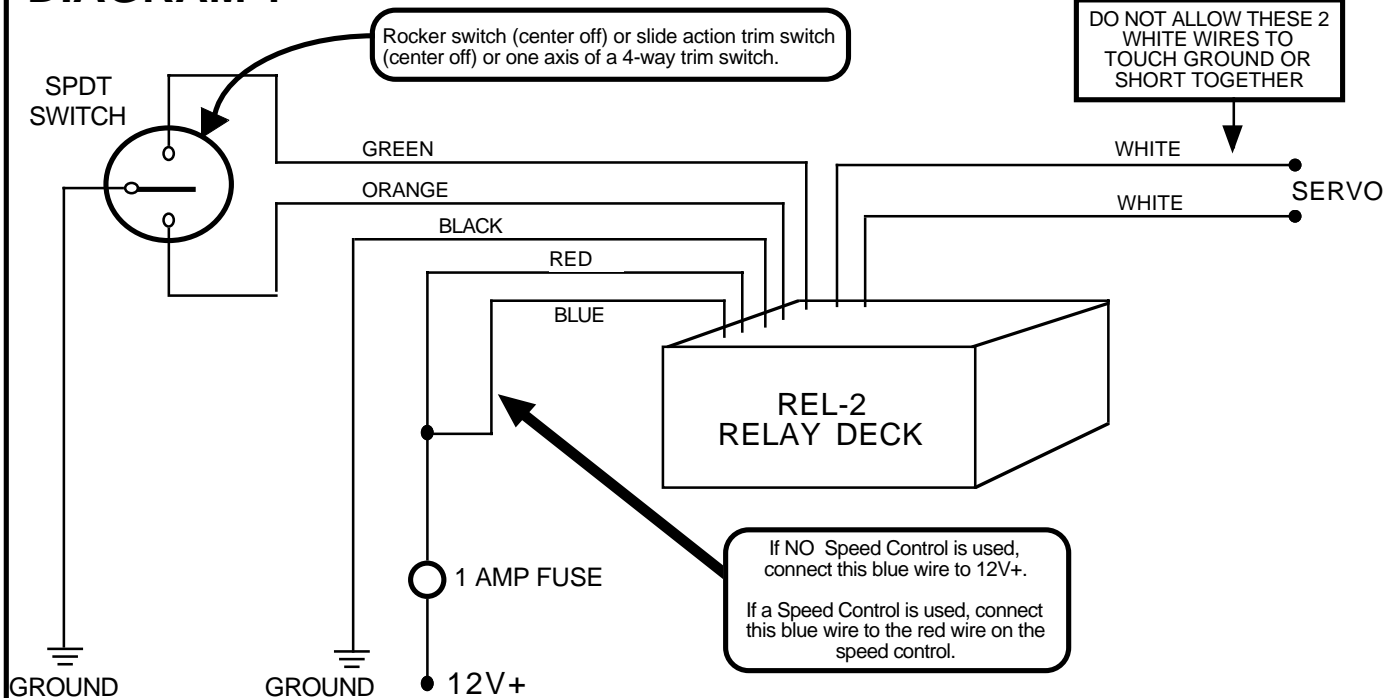

DIAGRAM 1



Warning: Installation and use of Ray Allen Company products is the responsibility of the aircraft designer and builder. Use of Ray Allen products in any application which will exceed their capability can cause failure leading to injury or death.

DIAGRAM 2

ROS-4 4-way Switch and REL-2 Relay Deck Installation Instructions

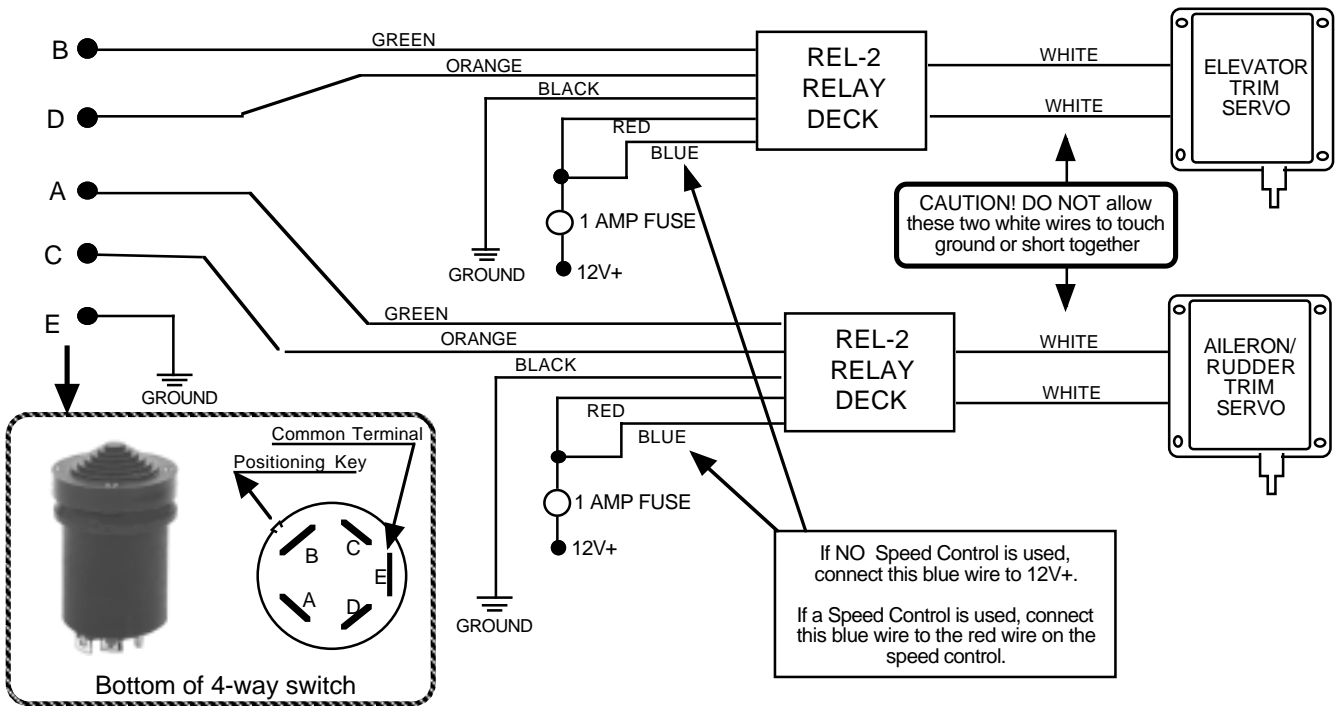

DIAGRAM 3

RAC Stick Grip and REL-2 Relay Deck Installation Instructions

