

# *The Ray Allen Company* Inc.

1341 Distribution Way Ste 15, Vista, CA 92081 USA Ph 760.599.4720 Fx 760.599.4383

[www.rayallencompany.com](http://www.rayallencompany.com)

## INSTALLATION INSTRUCTIONS FOR G205 AND G207 STICK GRIPS



**G205**



**G207**

**Warning:** Installation and use of Ray Allen Company products is the responsibility of the aircraft designer and builder. Use of Ray Allen products in any application which will exceed their capability can cause failure leading to injury or death.

# INTRODUCTION

The Ray Allen stick grip has been designed expressly for the needs of experimental aircraft builders. The push button switches in your stick grip can be used to actuate electric trim on aileron, elevator, or rudder. The button on the forward face of the grip is designed to be used as a push to talk (PTT) switch. The G207 grip has two additional switches on top that can be used to control radio frequency select, nav display switching, autopilot functions, etc.

Parts included with your Ray Allen stick grip kit:

Quantity	Description
1	Foam grip
1	Top case (with switches pre-installed)
1	Bottom case (with PTT switch pre-installed)
1	7/8" I.D. plastic sleeve
1	3/4" I.D. plastic sleeve
20 ft.*	26 gauge wire
4	2.25" long, pre-cut and stripped, 26 gauge wire pieces
3**	1.5" long, pre-cut and stripped, 26 gauge wire pieces
1	Self-adhesive label sheet

\*30 ft for G207 grips

\*\*7 for G207 grips

## ASSEMBLY

Some soldering will be required during the assembly of your stick grip. Here are some **helpful hints on soldering technique**:

- \* Use a small soldering iron (less than 40 watts) with a cone or round pointed tip. Keep the tip clean at all times.
- \* Use good quality, rosin core (60/40 tin/lead content is ideal). It's available at most hardware stores, or electronics stores such as Radio Shack.
- \* Let the soldering iron thoroughly warm up before attempting to solder.
- \* Push the stripped end of each wire through the holes in the switch's soldering tabs before applying solder. Otherwise, you would have to push the wire end through the solder (not easy).
- \* Place the tip of the soldering iron against the soldering tab and wire end. Let the tab and wire heat up for two seconds, then add solder to the joint. The solder should flow smoothly around the wire/tab junction.
- \* Remove the solder from the wire/tab joint just before removing the tip of the soldering iron.
- \* Do not use too much solder on the wire/tab joints. A big blob of solder is not acceptable on some joints (noted in instructions) because of possible interference with other parts. If you have too much solder on a joint, clean the soldering iron tip and heat up the joint. Excess solder will flow onto the tip and off the joint.
- \* A good solder joint will flow smoothly, and look glossy after cooling. A frosty and jagged looking solder joint indicates that the solder was not hot enough or the flux was allowed to burn away before the solder joint was completed.

### About the wires:

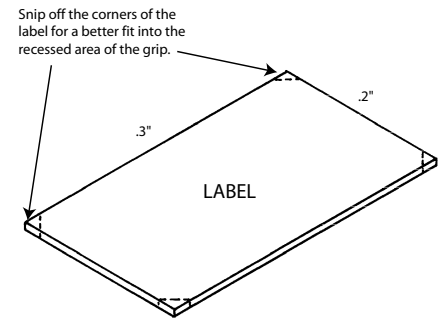
Your Ray Allen stick grip comes to you with pre-cut and stripped, 26 gauge, 19 strand, teflon insulated wires. Each of these wire pieces are cut to specific lengths for specific connections. In the following instructions, you will be told which wire lengths should go where, eliminating any guess work on your part. Please follow the wiring sequence shown in the instructions. If you do not route the wires exactly as shown, clearance problems will arise during final assembly of the grip.

## About the switches:

The switches in the stick grip are pre-installed at the factory. There are four ( six on the G207 model) switches in the top case, normally used for trim, and one switch in the bottom case, normally the push to talk (PTT). It may look like there is one long switch in the center of the top case, but there are actually two switches, mounted end to end (these are switches #1 and #3 in the drawings). The single pole double throw switches in the G205 stick grip are each rated for 5 amps, so they can be wired directly to your Ray Allen servos. The PTT switch can be wired directly to your radio. The tabs on some of the switches in the top case are pre-bent at the factory to provide necessary clearance. DO NOT bend these tabs back to vertical because they can easily break off. Both tabs are bent over on the PTT switch in the bottom case, again for clearance reasons.

## About the labels:

A die cut, Lexan covered label sheet is supplied in the kit. It is important to clean the recessed areas in the top case with alcohol to remove any oils that would prevent the adherence of the labels. The smallest labels (.3" x .2") tend to fit best if you carefully snip the corners before sticking them to the top case.

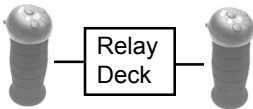


# WIRING INSTRUCTIONS

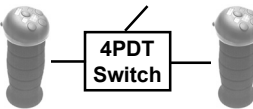
Before wiring the switches in your stick grip, you must decide how they are to be utilized.



\* **ONE GRIP** - If you are using only one stick grip, wire the switches as shown in Style 1 (page 4).



\* **TWO GRIPS** - If you are planning to install two stick grips in your plane so the copilot can also control the trim systems, you must wire the switches as shown in Style 2 using relays (pages 6&7). With this method either control stick can control the aircraft trims by simply pushing the buttons on the stick grip. This is the most popular method of wiring two stick grips.



\* **TWO GRIPS (ALTERNATIVE)** - If you want to install two stick grips, but do not want to use relays, you can install a switch that transfers control from one grip to the other. In this case, wire the switches as shown in the ALTERNATIVE version of Style 1 (page 5).

**The following diagrams only show the Ray Allen G205 stick grip. The G207 control stick grip has two additional pushbutton switches (OR toggle switches) installed in the top case. We do not supply wiring instructions for these additional switches because they can be used for a wide variety of functions on your aircraft or avionics.** However, we have supplied 10 extra feet of wire and 4 extra cut and stripped pieces. This should be more than enough to complete the wiring of the two extra switches.

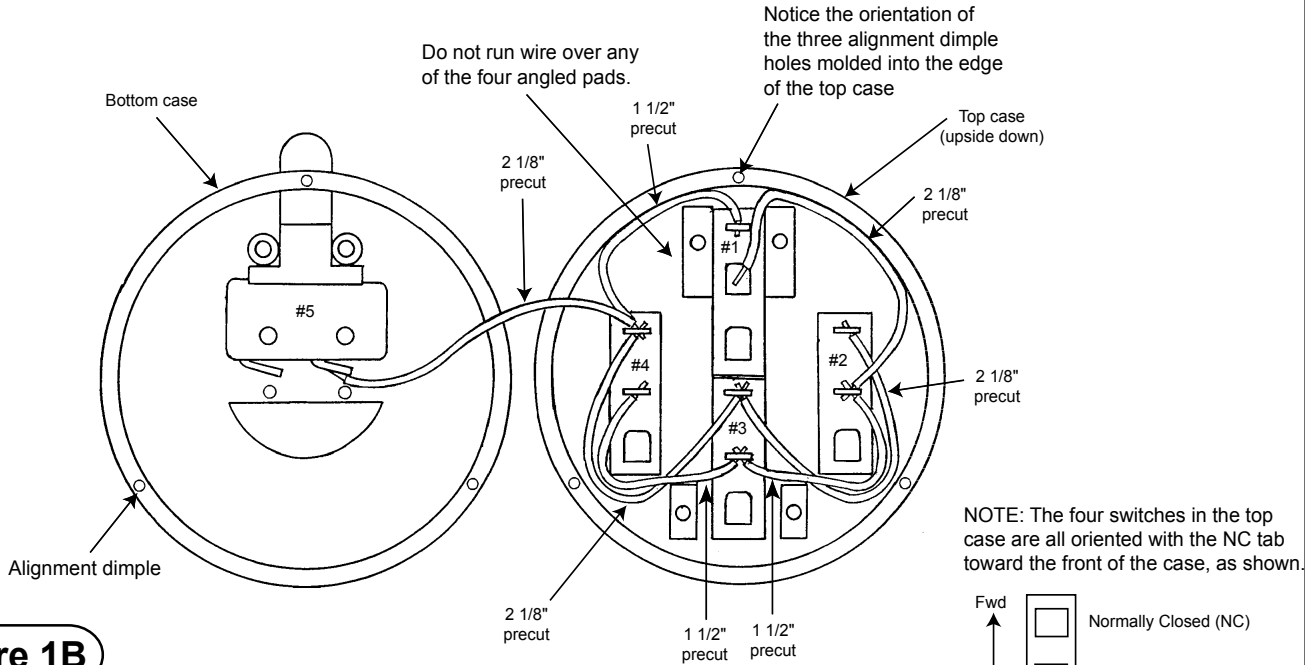
The Ray Allen stick grip comes to you with the top and bottom cases secured together with four screws. Remove these screws (located on the bottom of the bottom case) and separate the case halves for access to the internal switches. The alignment dimples on the cases are good orientation references to use while you wire your grip.

# WIRING STYLE 1

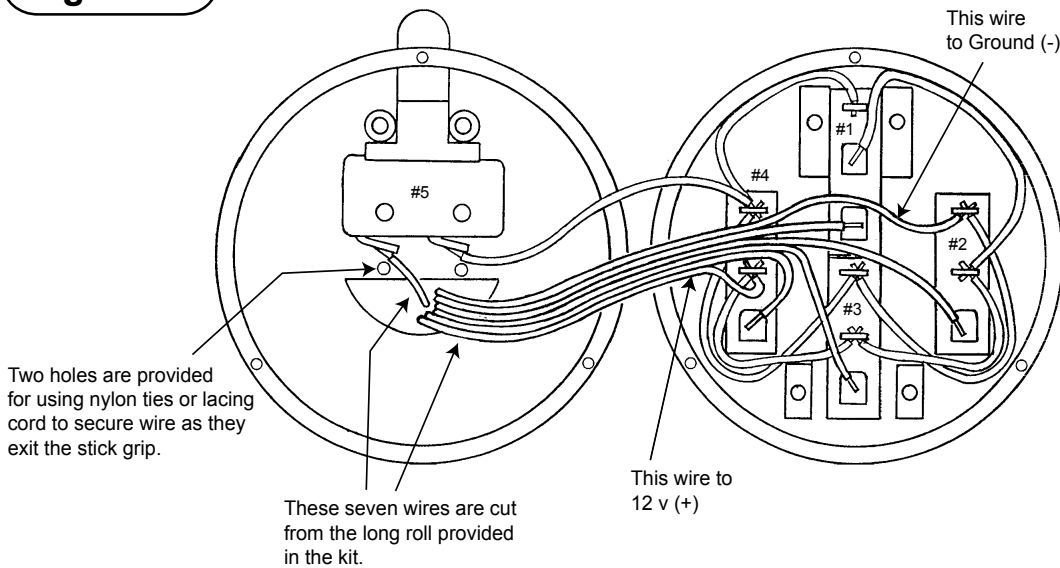
This wiring style will directly control Ray Allen trim servos using one stick grip. The wiring shown in the following diagrams can be completed with the seven pre-cut and stripped wire pieces included in your kit. The 20 ft. of wire (also included) can be cut into seven equal lengths and used to exit the grip and control stick. To avoid confusion after closing the top and bottom cases, be sure to mark each individual wire beforehand.

Begin the wiring by installing the pre-cut and stripped wire pieces, as shown in Figure 1A, then continue with the longer wires that you have cut, as shown in Figure 1B. A schematic is also provided on the following page.

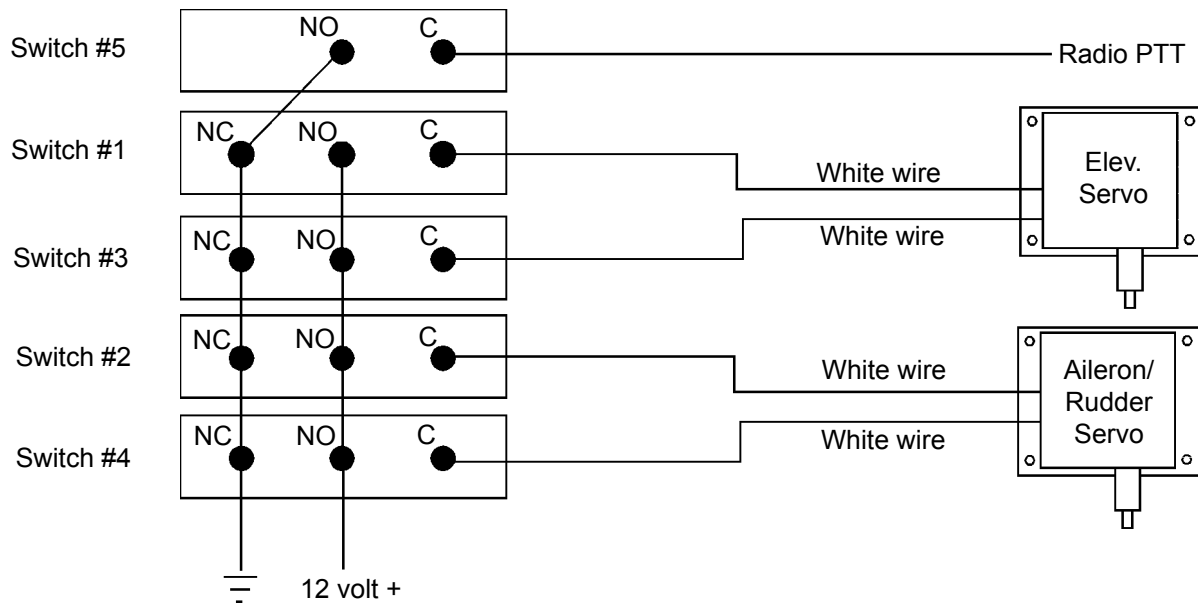
**Figure 1A**



**Figure 1B**



## WIRING SCHEMATIC FOR STYLE 1

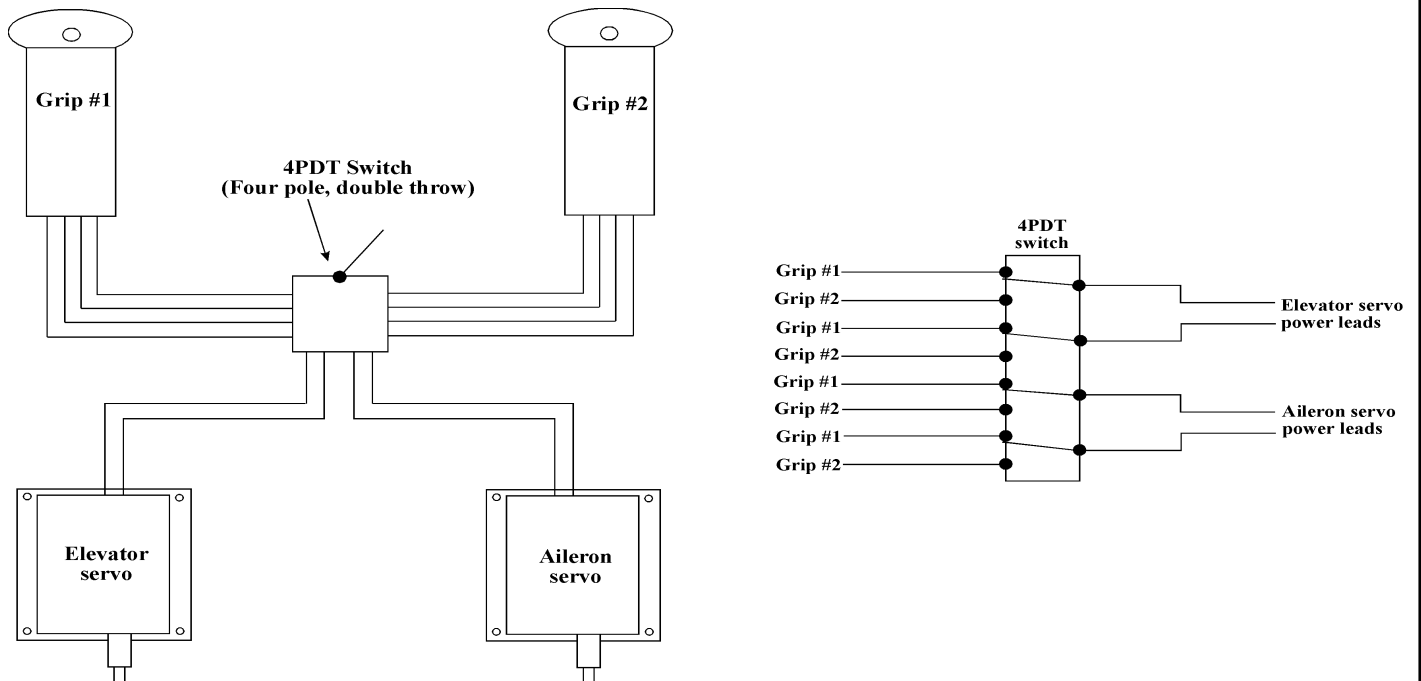


## WIRING STYLE 1 (ALTERNATIVE VERSION)

Use the wiring diagram below if you want to do any of the following:

- \*You have already installed one stick grip using wiring style 1 and now you want to install a second stick grip.
- \*You want to install two stick grips and do not want to use relay decks.
- \*You have Ray Allen rocker switches already installed and want to install a stick grip.

With this wiring method a 4PDT switch is used to transfer control of the trim servos from one stick grip to the other.

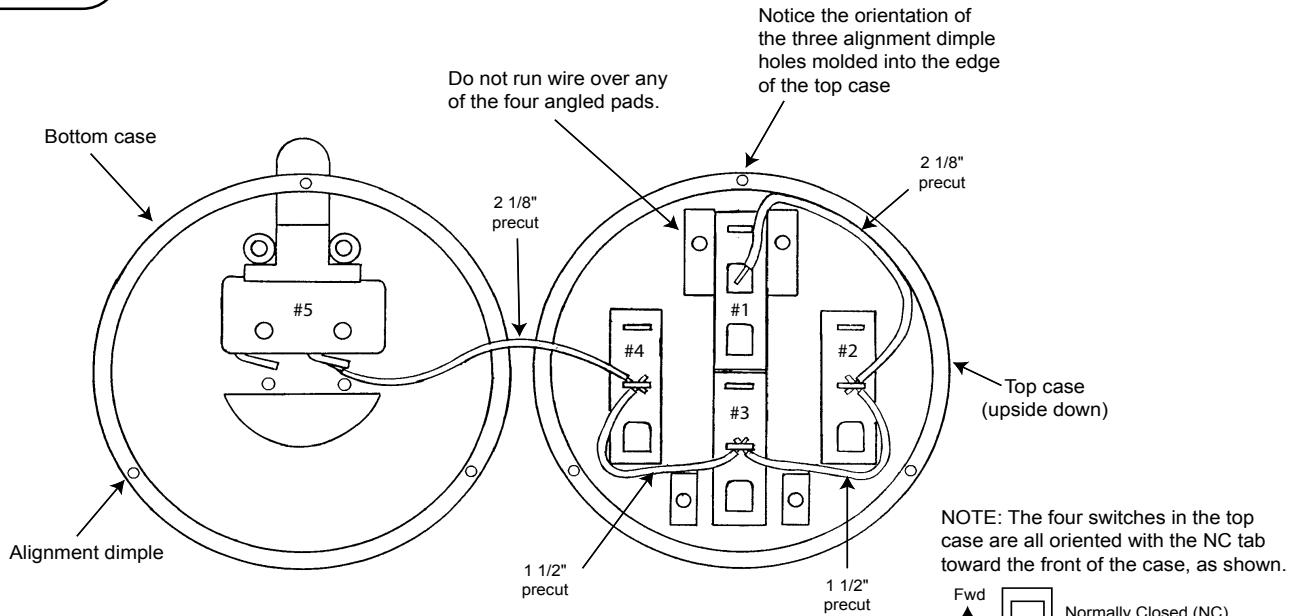


# WIRING STYLE 2

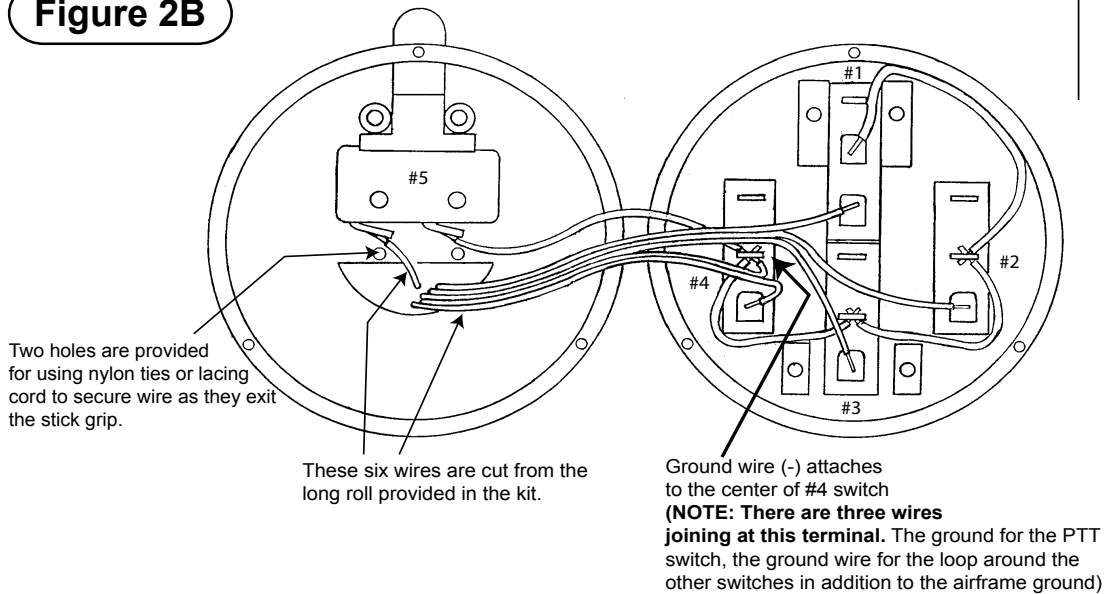
Typically, this wiring style is used when two stick grips are installed in the aircraft. With this method, either control stick can trim the aircraft by simply pushing the buttons on the stick grip. This wiring style uses only two terminals on each switch. This single momentary contact actuates Ray Allen relays to control the trim servos.

Begin the wiring by installing the pre-cut and stripped wire pieces shown in Figure 2A, then continue with the longer wires that you have cut, as shown in Figure 2B.

**Figure 2A**

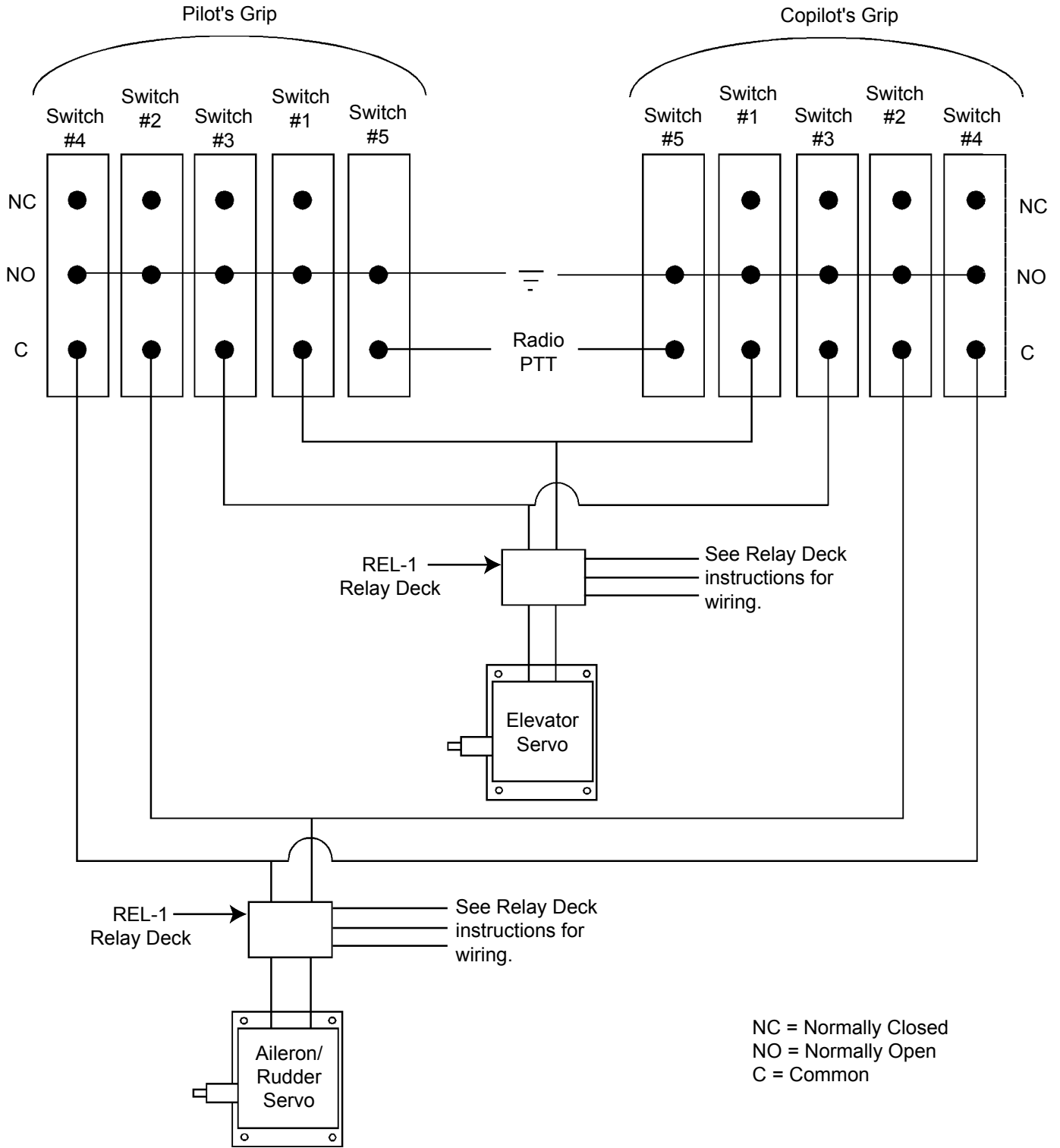


**Figure 2B**



# WIRING STYLE 2 (cont'd.)

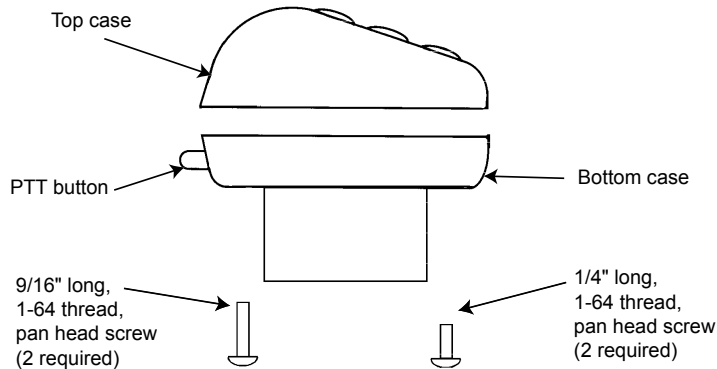
**Figure 2C**



## FINAL ASSEMBLY

The top and bottom cases are secured together with four, 1-64 thread screws as shown in Figure 3A. When mating the cases, be sure not to damage any wires in the process.

**Figure 3A**

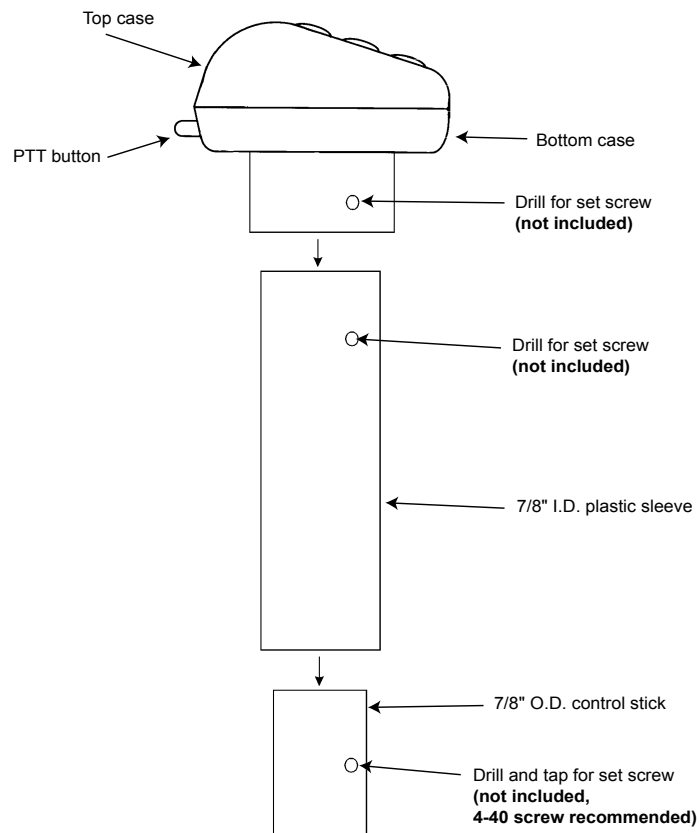


## STICK GRIP INSTALLATION

Plastic sleeves are provided to allow the stick grip to fit onto 3/4" or 7/8" diameter control stick tubes. Without the plastic sleeves, the stick grip will fit directly onto a 1" diameter control stick. To assist in pushing the foam grip over a 1" diameter tube, use a little soapy water as a lubricant (it's tight).

Figure 4A shows a sample installation onto a 7/8" control stick. If you have a 3/4" diameter control stick, simply substitute the 3/4" I.D. plastic sleeve.

**Figure 4A**



**Warning:** Installation and use of Ray Allen Company products is the responsibility of the aircraft designer and builder. Use of Ray Allen products in any application which will exceed their capability can cause failure leading to injury or death.