

# The Ray Allen Company Inc.

2525-8 Pioneer Avenue, Vista, CA 92081 USA Phone 760 599 4720 FAX 760 599 4383

www.rayallencompany.com

## Wiring diagram for using a RS2 Rocker Switch and a RAC Stick Grip

What you are doing with this method of wiring is making the RS2 rocker switch perform like two single pole, single throw (SPST) switches. The modified RS2 rocker switch then sends only a ground signal to the relay deck when activated. The relay controls the servo.

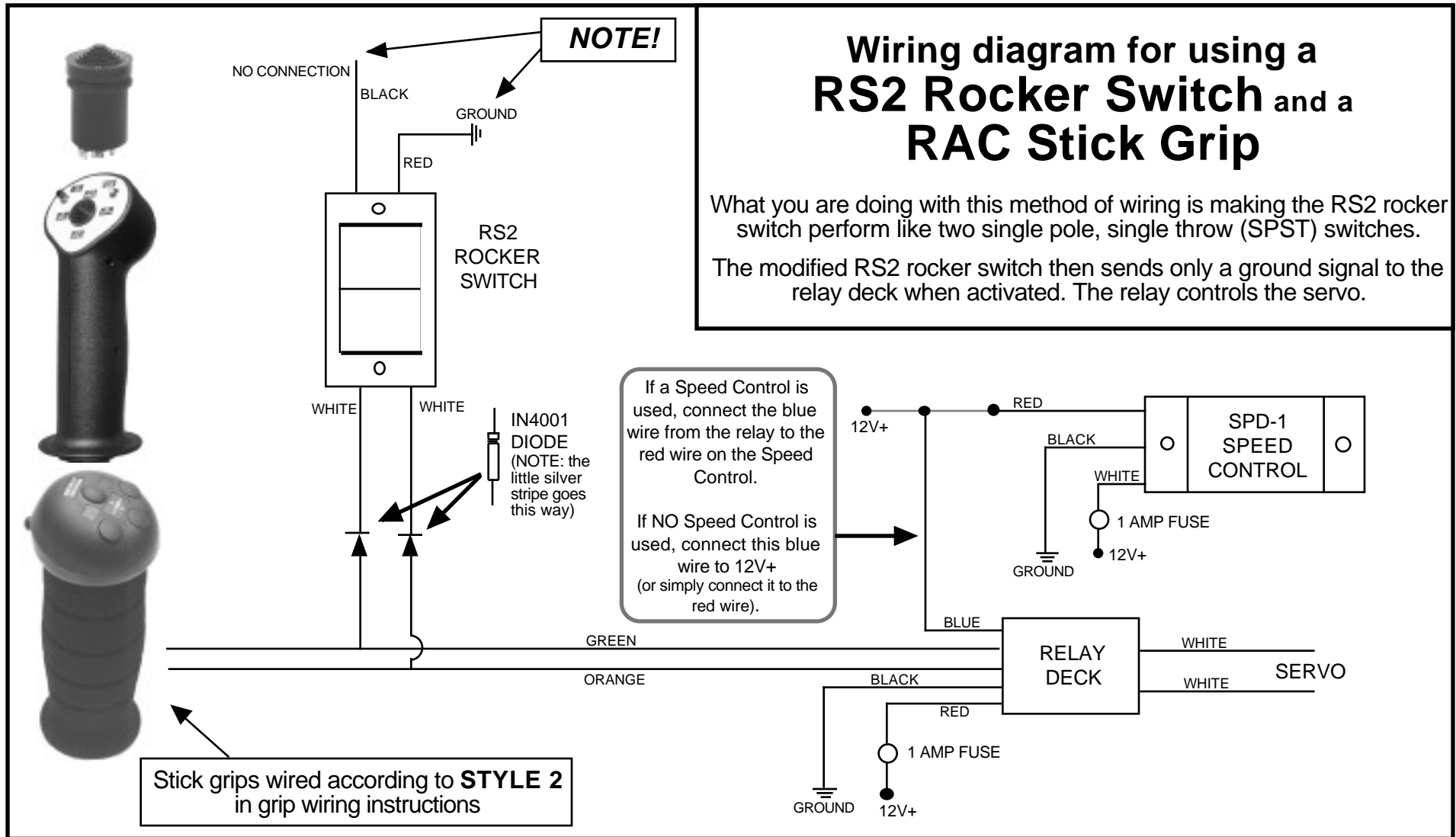

**Warning:** Installation and use of Ray Allen Company products is the responsibility of the aircraft designer and builder. Use of Ray Allen products in any application which will exceed their capability can cause failure leading to injury or death.